

These instructions are to be stored next to the water heater for reference purposes.

FOR YOUR SAFETY: This product must be installed and serviced by a professional service technician, qualified in hot water heater installation and maintenance. Improper installation and/or operation could create carbon monoxide gas in flue gases which could cause serious injury, property damage, or death. Improper installation and/or operation will void the warranty.

⚠WARNING

If the information in this manual is not followed exactly, a fire or explosion may result causing property damage, personal injury or loss of life.

Do not store or use gasoline or other flammable vapors and liquids in the vicinity of this or any other appliance.

WHAT TO DO IF YOU SMELL GAS

- Do not try to light any appliance.
- Do not touch any electrical switch; do not use any phone in your building.
- Immediately call your gas supplier from a nearby phone. Follow the gas supplier's instructions.
- If you cannot reach your gas supplier, call the fire department.

Installation and service must be performed by a qualified installer, service agency, or gas supplier.

TABLE OF CONTENTS

SECTION 1.

General Information

1A.	Introduction	3
1B.	Warranty Information	3
1C.	Unpacking	3
1D.	Heater Identification	3
1E.	Dimensions	3
1F.	Identifying Important Components	3
1G.	Placing the Water Heater	3
1H.	Gas Supply Piping	5
1I.	Combustion Air Supply	6
1J.	General Venting Instructions	7
1K.	Vertical Venting — Category I	7
1L.	Horizontal Venting — Category III	8
1M.	Water Piping	9
1N.	Electrical Wiring	10
1P.	Filling the Contractor Supplied Storage Water Tank	11
1Q.	Water Condition and Pump Requirements	11

SECTION 2.

Operating Instructions

2A.	Starting the System	14
2B.	Starting the System After Extended Shut-Down	15
2C.	Shut-Down Procedure	15
2D.	Extended Shut-Down — Cold Weather Areas	15

SECTION 3.

Maintenance and Service

3A.	Regular Maintenance	17
3B.	Recommended Annual Inspection	17
3C.	Cleaning the Heat Exchanger	17
3D.	Operating Sequence	17
3E.	Cleaning the Pilot and Main Burners	18
3F.	Electrical Troubleshooting	19
3G.	Parts Listing	21

SECTION 1. General Information

WARNING

To install this unit correctly, you **must** follow the procedures listed in this manual. If you do not do this, the warranty offered by Natco will be voided.

Follow the requirements of the local jurisdiction which has authority over the installation. In the United States, also follow the latest edition of the National Fuel Gas Code, ANSI Z223.1/NFPA54.

In Canada, the installation must conform with the latest edition of CAN/CGA B149.1 or .2 installation codes for gas burning appliances, and/or local codes.

Where the recommendations made in this manual are different from the national or local codes, the national or local codes should take precedence.

Do not make any changes to the water heater, or to its gas controls, gas orifices, wiring or draft inducer. Any modifications may void the warranty. If the unit must be modified because of special conditions, talk with a factory representative before beginning any changes.

1A. Introduction

This manual provides information necessary for the installation, operation, and maintenance of the Natco Mini-Nat Model NS00 water heater. This unit includes a blower for induced-draft venting, and has an advanced hot-surface proven-pilot ignition system.

The model designation is listed on the rating plate, which is attached to the top of the water heater.

Please read all application and installation procedures completely before doing the installation. If you have any problems or questions regarding this equipment, consult the factory, or local factory representative. Experience has shown that most operating problems are caused by improper installation.

1B. Warranty Information

The Natco Mini-Nat Model NS00 water heater is covered by a limited warranty. A copy of the warranty is printed on the back cover of this manual. The owner should fill out the warranty registration card and return it to Natco.

All warranty claims must be made to an authorized representative or directly to the factory. Claims must include the serial number and model of the unit. (This information is listed on the rating plate.) The claim must also include the

installation date and the name of the installer. Shipping costs are not included in the warranty coverage.

1C. Unpacking

Some accessory items are shipped in separate packages. Check to be sure you have received all of the packages which are listed on the packing slip. Inspect each item for damage immediately upon delivery. If there are any shortages or damage, tell the carrier right away. Any claims should be filed with the carrier. The carrier, not the shipper, is responsible for shortages and damage to the shipment whether the damage is visible or concealed.

1D. Heater Identification

To identify the unit, see the rating plate. Here is an explanation of the coding system:

1	2	3	4	5	6	7	8	9	10	11	12
T	L	0	0	-	1	9	9	N or P	S,H or I	K	X

Table 1. Heater Identification.

1st to 4th characters – series name (TL00)

5th character – dash (-)

6th through 8th characters – input rate (BTU/hr) x 1000

9th character – fuel

N = natural gas

P = propane

10th character - altitude (feet)

S = 0-2000 for natural gas, 0-5000 for propane

H = 2001-5000 for natural gas

I = 5001-10,000 for natural gas and propane

11th character - Heat Exchanger Type

K = Copper

12th character - X

1E. Dimensions

Figure 1 shows the dimensions of this unit.

1F. Identifying Important Components

Figure 2 shows the switches and sensors on this unit.

1G. Placing the Water Heater

This water heater is designed for *indoor* use only. The enclosure is not designed for outdoor installation.

1. Choose a convenient indoor location. Be sure that any leaking water from the connections will not damage the area near the appliance. If the unit must be installed on an upper floor of a multistory structure, ensure that any leaking water will not damage areas below the appliance. If a suitable location can not be found, install a

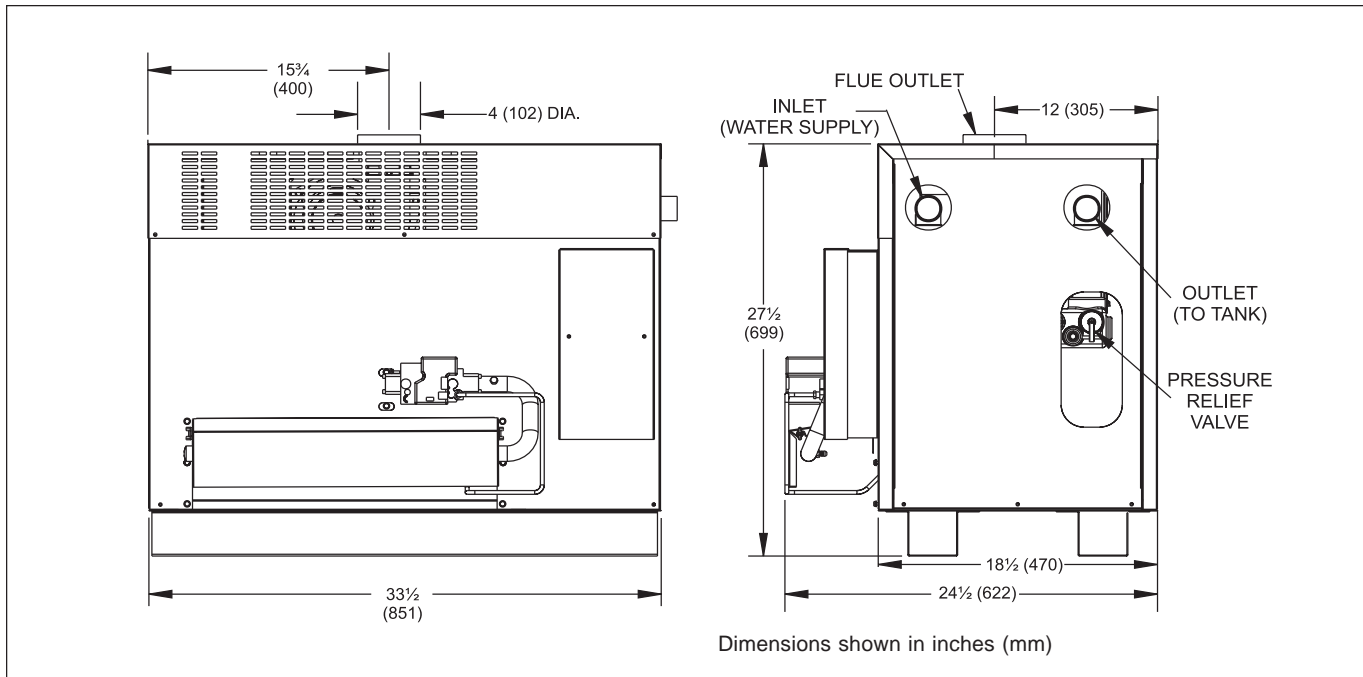

Figure 1. Dimensions.

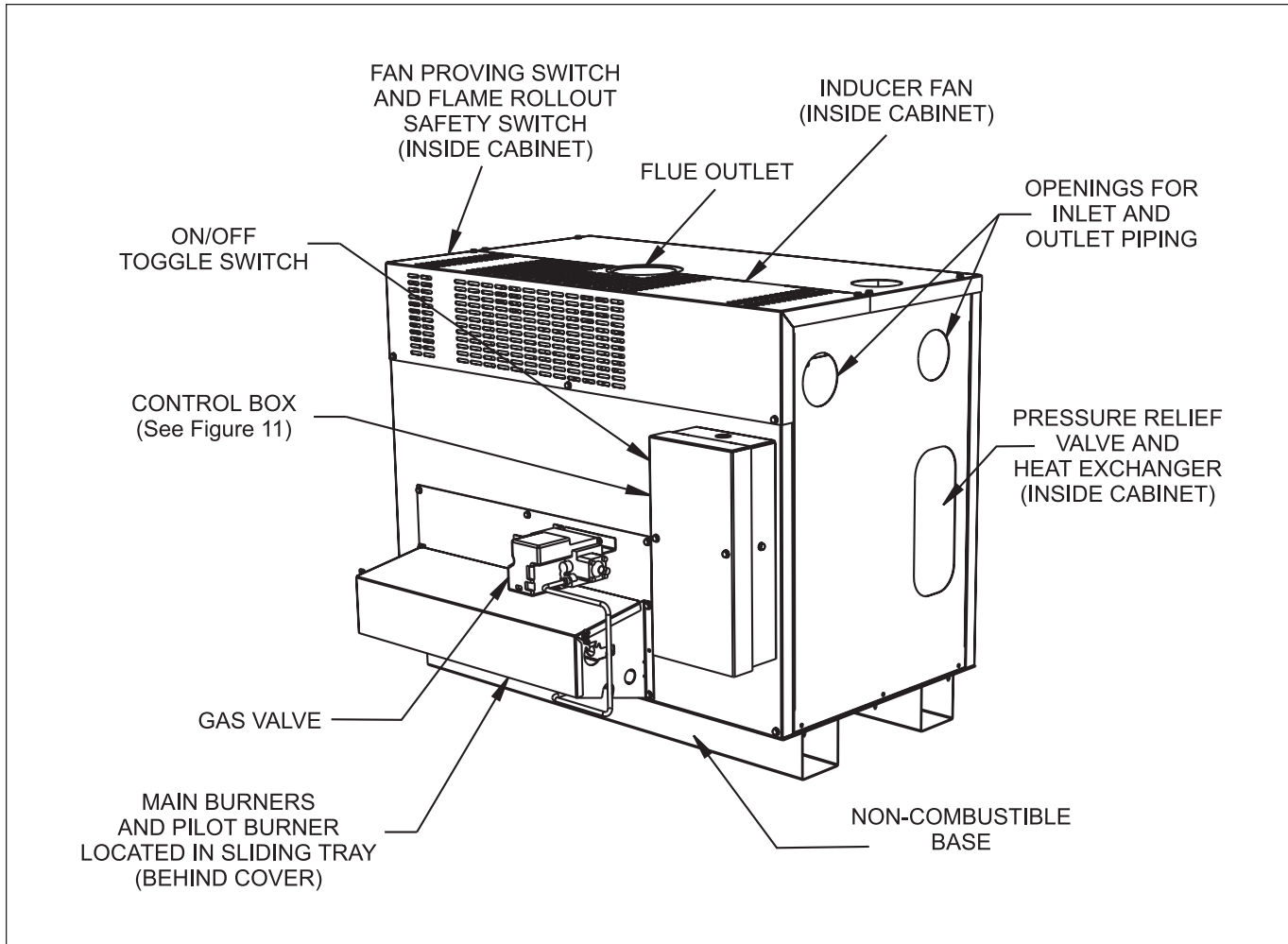

Figure 2. Component Locations.

drain pan under the appliance. Make sure the drain pan is properly piped to an adequate drain.

2. Place the water heater as close as possible to the vent or chimney.
3. For minimum clearances around the water heater, refer to Table 2. Maintain the minimum distances from all combustible surfaces (see Figure 3). The unit can be installed in a closet. Pay special attention to the air supply opening to the closet.

It is recommended that at least 12 inches (305mm) is allowed around the entire unit for maintenance, inspection, and plumbing access.

	Left Side	Right Side	Rear	Front	Flue*	Top
inches	6	6	2	2	6	18
<i>mm</i>	<i>152</i>	<i>152</i>	<i>51</i>	<i>51</i>	<i>152</i>	<i>457</i>

*One inch (25 mm) clearance using type B double wall vent pipe when vented vertically.

Table 2. Minimum Clearances from Combustible Surfaces.

4. This product may be installed on combustible flooring. Do not install directly on carpeting.
5. Be sure that the parts in the gas ignition system are protected from water when the water heater is operating or being served. Arrange water lines in the area so that water cannot drip or spray onto the water heater.

1H. Gas Supply Piping

Please review these instructions before installing the water heater.

1. Check that the water heater is fitted for the proper type of gas by checking the rating plate.
2. Natco water heaters are normally equipped to operate below a 2000 foot altitude. Water heaters

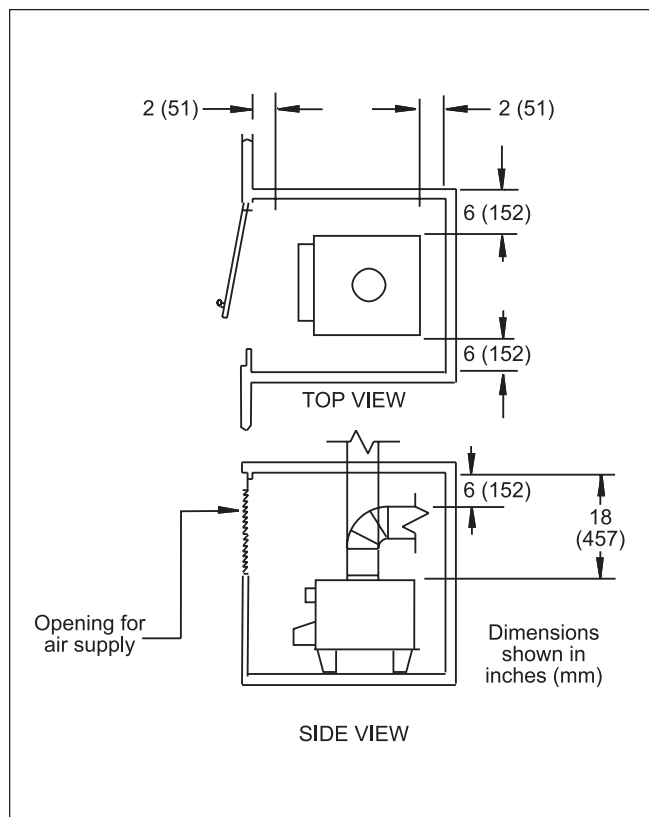

Figure 3. Installation in Closet.

equipped to operate at higher altitudes have appropriate information on the rating plate.

3. Use the figures in Table 3 to provide adequate gas piping from the gas meter to the water heater.
4. A sediment trap (drip leg) must be provided ahead of the gas controls (see Figure 4). A manual gas shutoff valve must also be provided for service, convenience and safety. This should be installed about 5 feet (1.5 m) above the floor. Check the local codes.

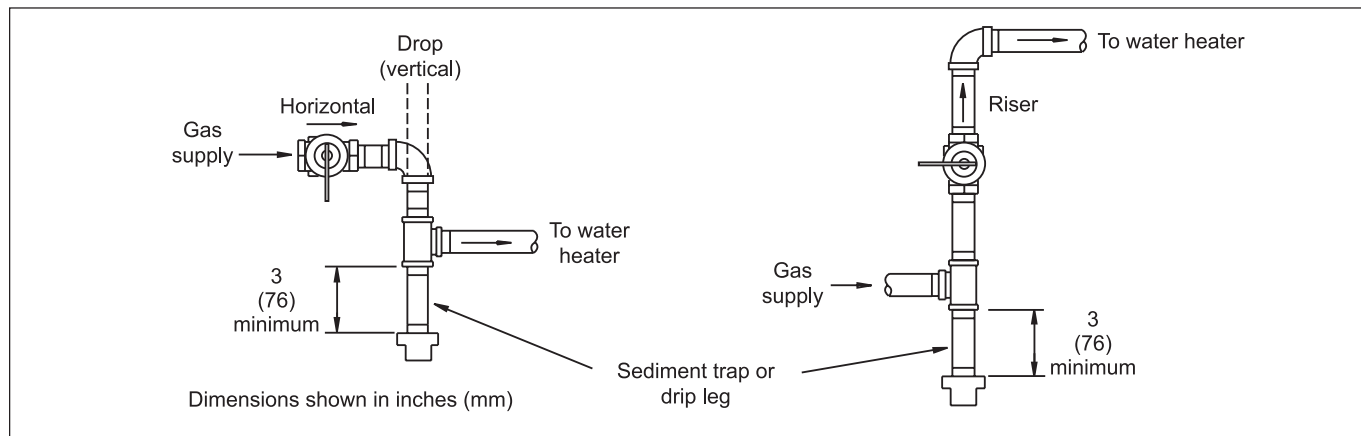

Figure 4. Gas Supply Piping.

- Turn off the water heater before you do any pressure testing on the gas lines.

If you will be testing at a pressure greater than 1/2" psig (3.5 kPa) –

Disconnect the gas line **before** the water heater and before the shutoff valve for the water heater.

If you will be testing at a pressure equal to or less than 1/2" psig (3.5 kPa) –

Turn off the manual shut off valve **ahead** of the water heater gas controls.

- Provide gas to the water heater at the pressure shown in Table 4. The regulator is preset at the factory, and normally requires no further adjustment.

Distance from Gas Meter		Pipe Size
0' – 200'	0 – 60 m	1¼"

NOTE: These figures are for Natural Gas (.65 Sp. Gr.), and are based on 1/2" water column pressure drop. Check supply pressure with a manometer, and local code requirements for variations. For LPG, reduce pipe diameter one size, but maintain a 1/2" minimum diameter. A "normal" number of Tees and elbows have been taken into allowance.

Table 3. Gas Piping Size.

	Water Column			
	Natural Gas		Propane (LP)	
	i.w.c.	kPa	i.w.c.	kPa
Minimum Supply Pressure*	6	1.5	11	2.7
Maximum Supply Pressure**	10	2.5	14	3.4
Manifold Gas Pressure	4	1.0	9	2.2

* Listed for purposes of inlet adjustment.
 ** The gas supply should not exceed this pressure.

Table 4. Gas Pressure Measurement.

Note: When measuring the inlet supply pressure, the water heater and all other gas appliances sharing the water heater gas supply line must be firing at maximum capacity. Low gas pressure could be caused by an undersized gas meter or an obstructed gas supply line.

- Before operating the water heater, the complete gas supply system and all connections must be tested for leaks using a soap solution.

 **Caution**

Some solutions used for leak testing may cause corrosion or stress cracking. (These include soap and water.) To prevent this, rinse the piping with water after testing.

11. Combustion Air Supply

The water heater location must provide enough air for proper combustion and ventilation of the surrounding area. See the latest edition of ANSI standard Z233.1 or in Canada, CAN/CGA-B149.1 or .2, and any local codes that may be applicable.

In general, these requirements specify that if the unit is installed in a confined space, there must be at least two permanent air supply openings. One opening should be within 12 inches (305mm) of the ceiling, and the other should be within 12 inches (305mm) of the floor.

For installation in U.S.A.:

Water Heater Size	Outside Air Area†	Inside Air Area††
199	50 sq in 323 sq cm	199 sq in 1284 sq cm

The area indicated is for one of two openings; one at floor level and one at ceiling, so the total net free area would be double the figures indicated. For special conditions, refer to NFPA54 ANSI Z223.1.

† Outside air supply – Combustion air is supplied directly through an outside wall.

†† Inside air supply – Combustion air is supplied from inside the building.

NOTE: Check with louver manufacturers for Net Free Area of Louvers. Correct for screen resistance to the New Free Area if a screen is used.

Table 5. Minimum Recommended Air Supply to Water Heater Room.

Outside Air Supply: When combustion air is supplied directly through an outside wall, each opening should have a minimum free area of one square inch per 4,000 BTUH input of the total input rating of all appliances in the enclosed area.

Inside Air Supply: When combustion air is supplied from inside the building, each opening should have a minimum free area of one square inch (6.5 sq cm) per 1,000 BTUH input of the total input rating of all appliances in the enclosed area. These openings should never be less than 100 square inches (645 sq cm).

For installation in Canada:

NOTE: In Canada, follow Canadian Standard CAN/CGA-B149 or local codes.

Exhaust Fans or Vents: Any equipment which exhausts air from the room around the unit can deplete the combustion air supply. Such equipment can also reverse the action of the venting system. This could cause flue products to accumulate in the space where the water heater is installed. Additional air must be supplied to compensate for any exhaust effect.

The information in Table 5 is not applicable in installations where exhaust fans or blowers of any type are used. Such installations must be designed by qualified engineers.

If a blower or fan is used to supply air to the water heater room, the installer should make sure it does not create drafts which could cause nuisance shutdowns. If a blower is necessary to provide adequate combustion air to the water heater, a switch or equivalent must be wired into the water heater control circuit to prevent the water heater from firing unless the blower is operating.

The water heater must be protected from any source of corrosive chemical fumes including those emitted by trichlorethylene, perchlorethylene, chlorine, etc.

1J. General Venting Instructions

WARNING

This water heater must be vented in accordance with Part 7, Venting of Equipment, of the latest edition of the National Fuel Gas code, ANSI Z223.1 and all applicable local building codes. In Canada, follow CAN/CGA B149 Installation codes. Improper venting of this appliance can result in excessive levels of carbon monoxide which can result in severe personal injury or death!

Here are some general rules to follow when venting this unit:

- Place the water heater as close as possible to the vent or chimney.
- The vent collar on the water heater must be fastened directly to an unobstructed vent pipe. Use rustproof sheet metal screws no longer than 1/2" (13 mm).
- Do not weld the vent pipe to the water heater collar. The weight of the stack must not rest on the water heater. The top of the water heater must be easily removable for normal service and inspection of the unit.
- The water heater vent **must not** be connected to a fireplace, wood stove or other equipment which burns solid fuel.
- Avoid terminating the water heater vent near any air-conditioning or air-supply fans. These fans can pick up the exhaust flue products from the water heater and return them to the building. This can create a health hazard.

- Avoid using an oversized vent pipe or using extremely long runs of the pipe. This may cause excessive cooling and condensation of flue gases.

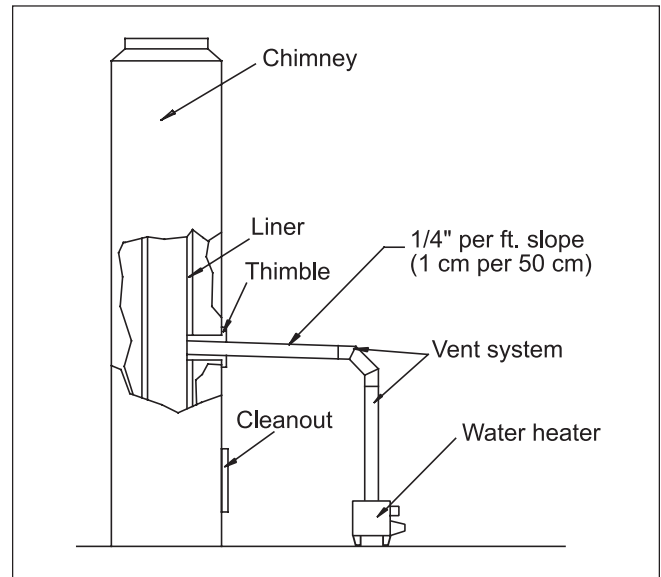

Figure 5. Chimney Venting.

1K. Vertical Venting – Category I

This unit can be vented into a masonry chimney, provided several conditions are met (see Figure 5.)

- The chimney must have an appropriate tile lining. The lining should be the correct size, should be constructed correctly, and must be clean.
- Check the chimney passage way to be sure that it is clear and free of obstructions.
- If the chimney must be rebuilt, follow nationally-recognized standards. (See the National Building Code or ANSI/NFPA 211).
- When the water heater and a boiler are to be connected to the same chimney, each unit must have its own vent connector. The two connectors must enter the chimney at least 6" (152 mm) apart.

(a) Vent Connections

Use type B double wall or type C single wall gas vent pipe (26 gauge, minimum thickness) from the water heater to the chimney. Natco recommends installation of a riser with a minimum of 12" (305 mm) height above the water heater. The vent system should be sloped up toward the chimney at a rate of 1/4" per foot (1 mm per 50 mm). The vent connector must be strong enough to support the weight of the

material used. This will maintain the clearances and prevent physical damage and separation of the joints.

NOTE: Always provide a minimum clearance of 6 inches between a Type C vent pipe and any combustible materials.

Warning

Single-wall vent pipe must *never* pass through interior walls, or through floors or ceilings! Failure to comply with this warning could result in a fire, causing property damage, personal injury, or death!

When installing the vent system, all applicable national and local codes must be followed! If you install thimbles, firestops or other protective devices, and they penetrate any combustible or noncombustible construction, be sure to follow all applicable national and local codes.

If a vertical vent is installed, follow the code requirements for Category 1, Fan Assisted Appliances. Follow the requirements as indicated in the latest edition of ANSI Z223.1/NFPA 54. See “Sizing of Category I Venting Systems” and “Appendix G.” In Canada, follow the instructions in the CAN/CGA-B149 installation code.

An unused chimney can be used as a raceway for a single-wall vent pipe. (See Figure 6). Never run a vent pipe through a flue that has another appliance attached to it.

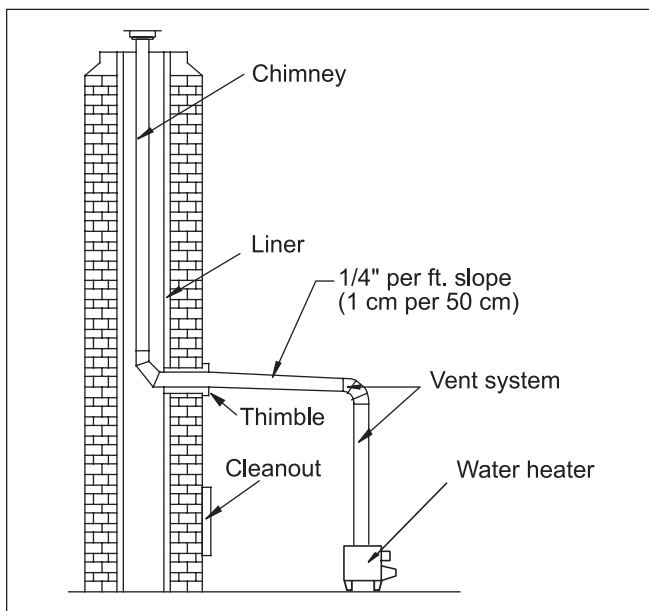

Figure 6. Vertical Venting.

(b) Vent Termination

A listed vent terminal must complete the vertical run where it exits the chimney. This must be designed for the type of pipe being used. The vent pipe must extend at least 3 feet (1 m) above the highest point where it passes through the roof. In addition, the vent cap must be at least 2 feet (0.6 m) higher than any part of a building within a horizontal distance of 10 feet (3 m). Clearance to any combustible materials must be maintained as listed. (See Figure 7).

1L. Horizontal Venting – Category III

When a vent system is horizontal or cannot meet the requirements of Category I, it can develop positive pressure. This type of system must be installed in accordance with the instructions in this section, and with the instructions supplied by the vent manufacturer.

(a) Vent connections

The vent system *must be gas tight*. All seams and joints must be sealed with silicone sealant or adhesive tape having a minimum temperature rating of 400°F (204°C). (See Table 6 for a list of approved sealing materials).

For best results, a horizontal vent system should be as short and straight as possible. The materials used in the vent connectors should be as listed in Table 7.

Description	Manufacturer	Product
High Temperature RTV	Dow Corning	Trade Mate
2" (51 mm) wide aluminum foil tape, backed with adhesive	Venture	Product #3243
2" (51 mm) wide aluminum foil tape backed with adhesive	3M	Product #433

Table 6. Vent Sealing Material.

<p>In USA: Use UL type 304, 316 or 29-4C stainless steel, 26 gauge minimum.</p> <p>In Canada: Use “BH” vent type complying with ULC S-636 Standard.</p>	<p>Up to a maximum of 40 feet (12 m) of equivalent pipe run (including required elbows).</p>
---	--

Table 7. Vent Connector Materials.

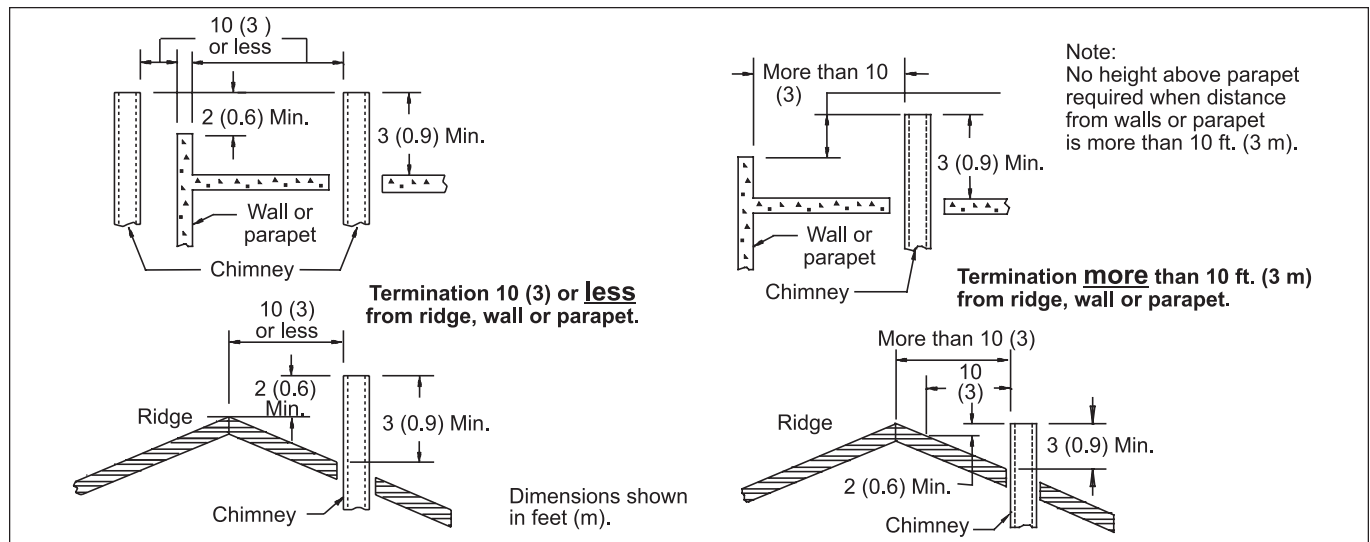

Figure 7. Vertical Vent Termination.

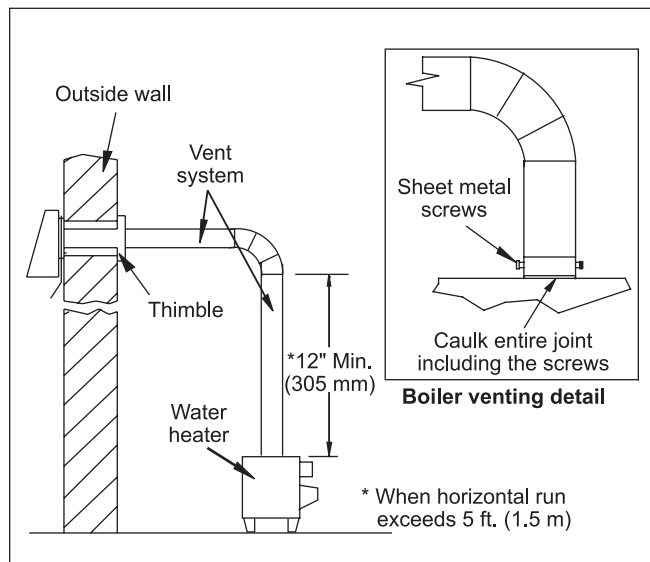

Figure 8. Horizontal Venting.

The water heater vent collar must be fastened to vent pipe of the same diameter, with rustproof metal screws no longer than 1/2" (13 mm) and sealed with high temperature – 500°F (260°C) – silicone sealant. For larger diameter vent pipes, use a sealed reducer fastened directly to the water heater collar and seal all joints as indicated in Figure 8. Allow the sealant to cure for 24 hours before operating the water heater.

The entire vent system must not exceed the size specified in Table 8.

The following criteria must be observed:

- Attach a vertical pipe at least 12 inches (305 mm) high to the water heater outlet before the horizontal run if run exceeds 5 feet (1.5m) (see Figure 8).

- Support the vent run at 3-foot (1 m) intervals with overhead hangers.
- Pitch down the vent run, toward the vent terminal (hood), at a rate of 1/4 inch per foot (1 cm per 50 cm).
- Do not locate any joint screws at the bottom of the vent run.

Diameter	No. of Elbows	Horizontal Run Length*
4" 102 mm	4	20' 6 m

*For each elbow eliminated, add 5 feet (1.5 m) of allowable vent.

Table 8. Horizontal Venting Configuration.

(b) Vent Termination

A side wall vent terminal (hood) must be used when the water heater is vented through a side wall. Use Natco Part Number D2004300, 4" (102 mm) dia. The vent hood provides a means of installing vent pipe through the building wall, and must be located in accordance with ANSI Z223.1/NFPA 54, or in Canada CAN/CGA-B149 and local applicable codes (see Figure 9.)

Locate the vent terminal so that it cannot be blocked by snow. Most codes require that the termination be at least 12 inches (305 mm) above grade, but the installer may determine it should be higher depending on local conditions.

1M. Water Piping

1. To prevent damage to the unit, all soldering must be done before making any connections to the heater or the tank.

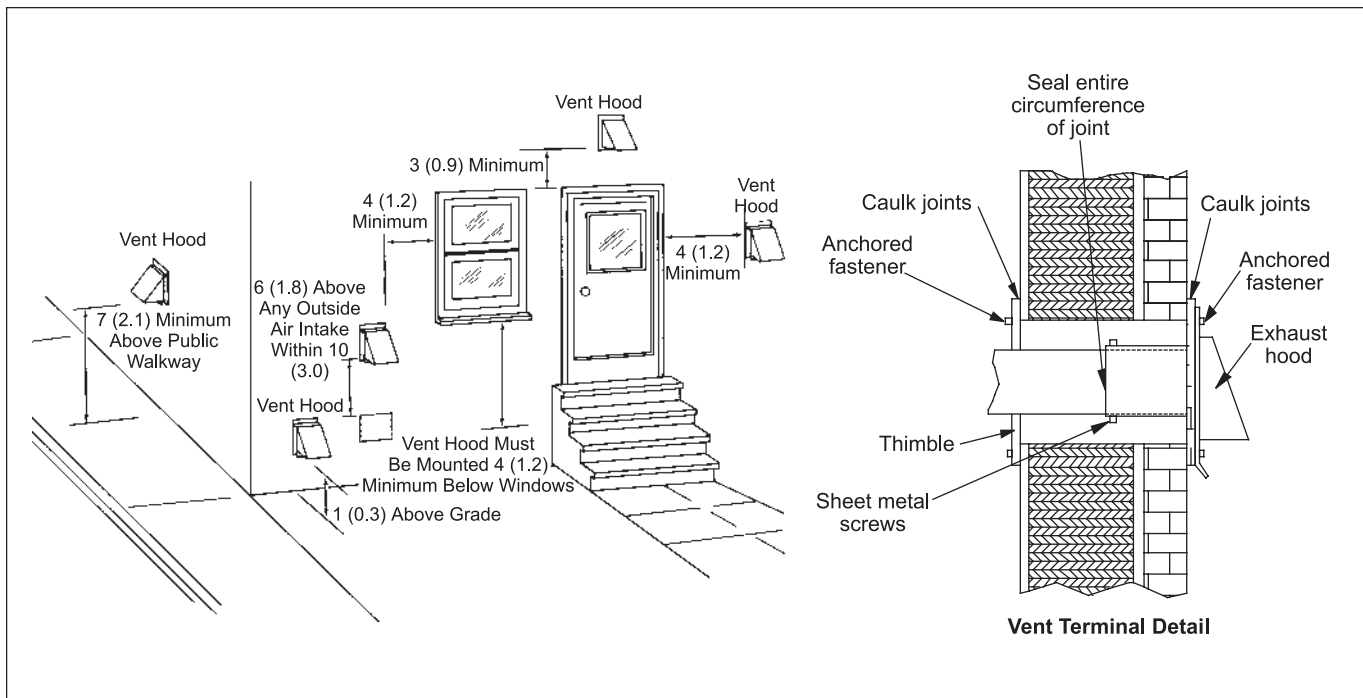

Figure 9. Horizontal Vent Terminations.

2. If a backflow preventer, pressure reducing valve, or check valve is included in the cold water supply line, you must provide a way to control thermal expansion of the water in the tank. This will prevent the temperature and pressure relief valve from being forced open repeatedly. For advice on controlling this situation, contact the water supplier or local plumbing inspector. Install an expansion tank of the proper size, as shown in Figure 10.
3. The discharge piping for the pressure relief valve must be directed so that the hot water cannot splash on anyone. Attach the run-off tube to the pressure relief valve, and run the end of the tube to within 6" (152 mm) of the floor. Do not install any reducing couplings, valves, or any other type of restriction in this line. This run-off tube must be installed to allow free and complete drainage of both the valve and the run-off tube.

⚠ WARNING

Don't install the run-off tube so the end terminates outdoors. This could allow a freezing condition to plug the end of the pipe. If the run-off tube is allowed to remain blocked, an explosion may result. This can cause property damage, personal injury, or death.

NOTE: Ensure expansion tank pressure rating is sufficient to withstand system operational pressure.

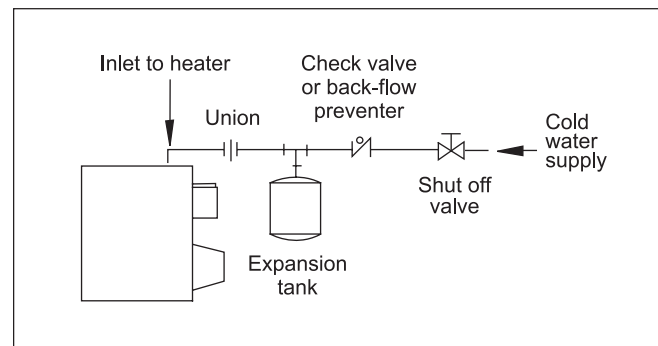

Figure 10. Expansion Tank Installation.

1N. Electrical Wiring

1. Check the voltage, frequency, and phase of the wiring to the water heater. This unit is designed to operate on 115V AC, 60 Hz, single phase. (The controls and switches on this unit operate on 24V AC. This voltage is produced by a transformer and draws less than 12A.)
2. A means of switching off 115V AC to the unit is provided by a 3 position toggle switch on the control panel. Additional switches or connections may be required by local authority. If there are no local requirements, follow the latest edition of the National Electrical Code, ANSI/NFPA 70 in the U.S. In Canada, follow the latest edition of CSA C22.1 Canadian Electrical Code, Part 1.

⚠ WARNING

The boiler must be electrically grounded. Follow the requirements of the local authority having jurisdiction. In the absence of such requirements, follow the latest edition of the National Electrical Code ANSI/NFPA 70 in the U.S., or the latest edition of CSA C22.1 Canadian Electrical Code, Part 1, in Canada. Do not rely on the gas or water piping to ground the metal parts of the boiler. Plastic pipe or dielectric unions may isolate the boiler electrically. Service and maintenance personnel who work on or around the boiler may be standing on wet floors, and could be electrocuted by an ungrounded boiler.

3. The 3 position switch is configured as follows:
 - Middle Position All power to the unit is shut off.
 - 'Down' Position Boiler On, pump in automatic mode. The pump will shut off 3 minutes after the call for heat is satisfied.
 - 'Up' Position Boiler On, pump in constant mode. The pump will continue to run after the call for heat is satisfied.
4. To make the wiring connections, remove the two screws which attach the front cover of the control box.
5. There are two sets of wires near the top of the control box (see Figure 11). These wires are for connection to the 115V AC lines. Connect the hot lead from the 115V power supply to the black wire. Connect the three white wires to the neutral side of the 115V line (see Figure 12).

1P. Filling the Contractor Supplied Storage Water Tank

⚠ Caution

Air must be removed from the heater and the tank before the unit is operated. If this is not done, the heat exchanger may be damaged.

1. Open the hot water faucet(s) to allow air to escape.
2. Open the shut-off valve(s) in the cold water supply line.
3. Open the shut-off valve(s) in the hot water supply line.
4. Turn off the gas to the unit, but allow the pump to run for about 15 minutes. This will allow any remaining air to collect in the top of the tank.

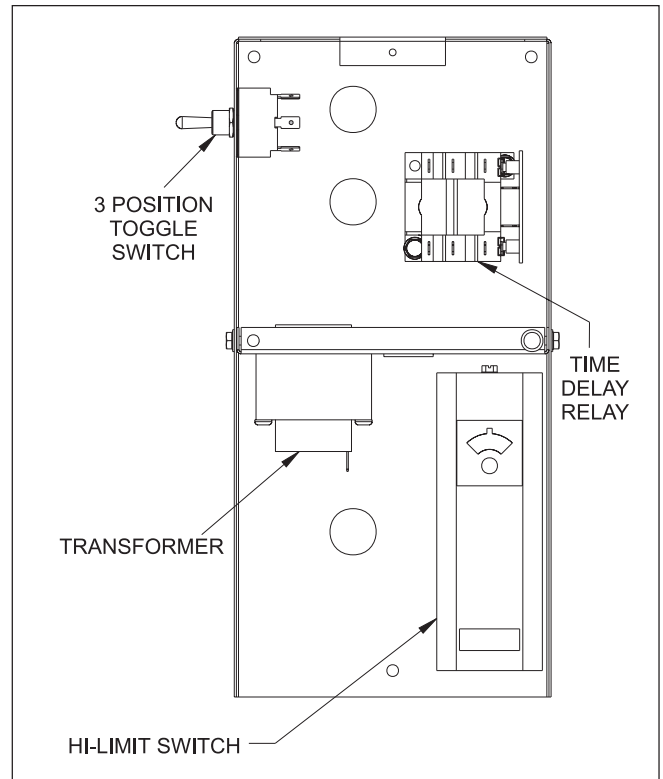

Figure 11. Location of Parts in Control Box.

5. Open the pressure relief valve to remove any remaining air.
6. Turn on the gas and check for leaks. Now the unit is ready to operate.

1Q. Water Condition and Pump Requirements

Natco equipment is designed to be used in a variety of water conditions. With the proper pump, the water velocity within the heat exchanger tubes is kept high enough to prevent scaling from hard water, and low enough to avoid erosion from soft water.

Water hardness must be considered when selecting a pump for this unit. Table 9 identifies the water hardness categories and their hardness composition.

Hardness Category	Grains per Gallon	Parts per Million
Soft	1 through 7.5	17 through 128
Normal	7.6 through 17	129 through 291
Hard	Over 17	Over 291

Table 9. Water Hardness.

This unit is designed to operate with inlet water temperatures that are greater than 100°F. Water temperatures greater than this will ensure that condensation of flue gas inside the combustion chamber is greatly minimized.

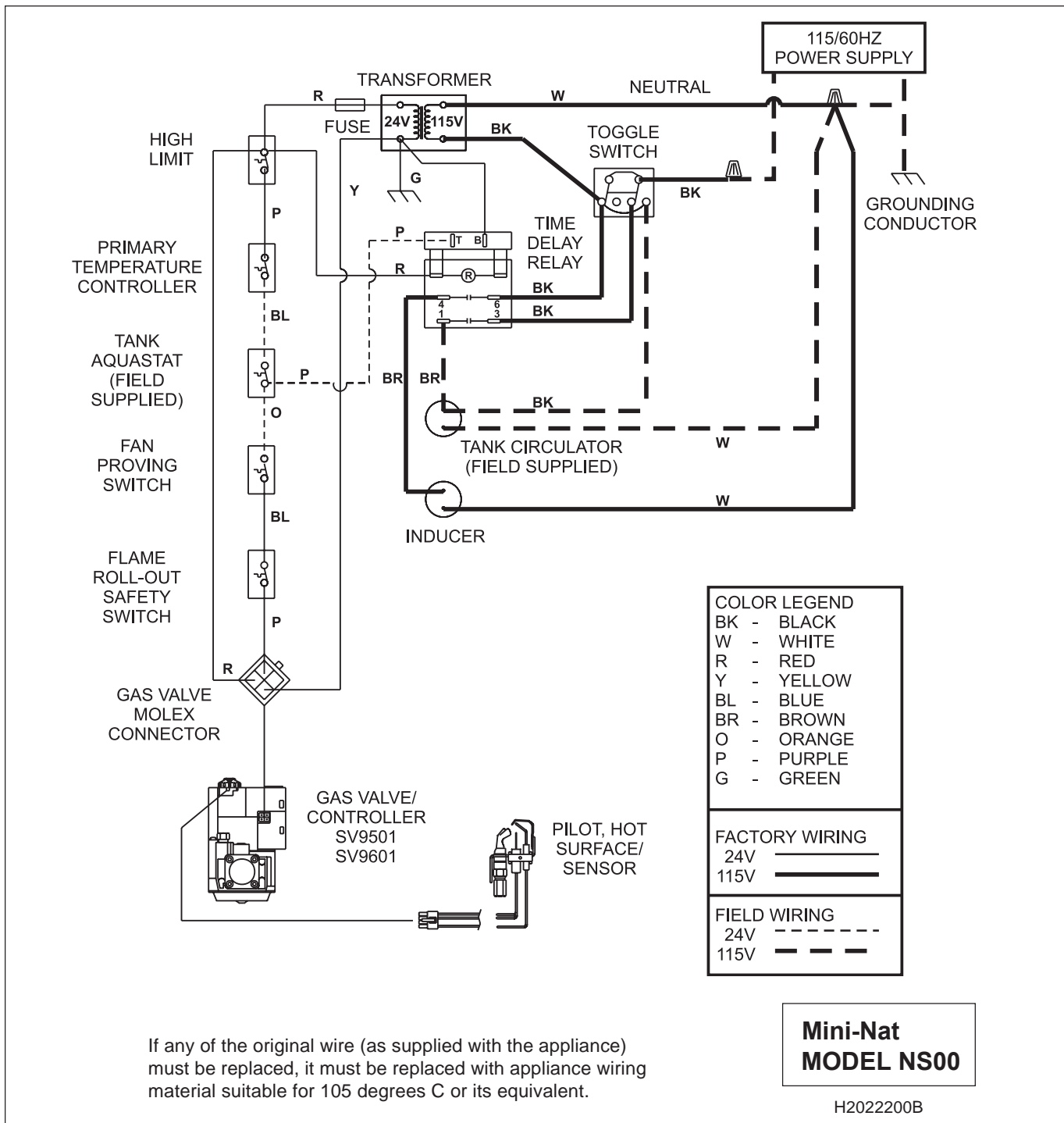

Figure 12. Connection Diagram.

Table 10 lists the flow and pressure drop requirements for the NS00-199. These values provide the proper circulation between the water heater and a storage tank. The pressure drop values listed include some nominal piping:

- 30 feet of 1½" nominal ID copper pipe
- Six - 1½" of 90° copper elbows.

Model	Water Category	Flow Rate		Pressure Drop		Water Temp Rise	
		GPM	L/sec	ft	m	F°	C°
NS00-199	Soft	17	1.1	9	2.7	20	11
	Normal	17	1.1	9	2.7	20	11
	Hard	22	1.4	15	4.6	15	8

Table 10. Flow and Head Requirements.

*Pressure drop includes head loss of the heat exchanger and 30 feet (9.1m) of 1½" copper pipe and six 90° elbows.

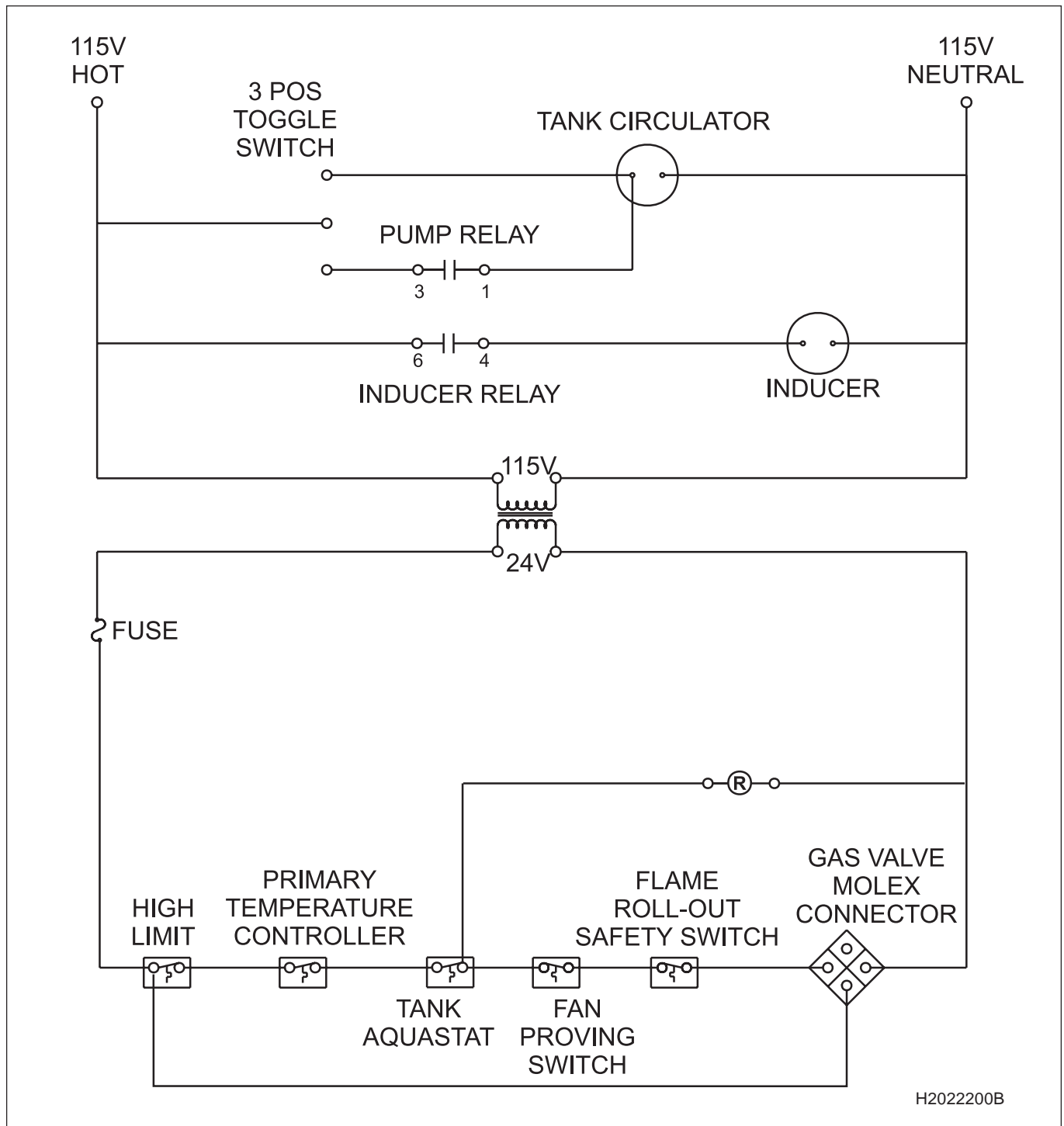

H2022200B

Figure 13. Wiring Schematic.

If the loop between the heater and storage tank comprises more than this nominal piping, larger diameter pipe or a larger pump should be considered.

SECTION 2. Operating Instructions



DANGER

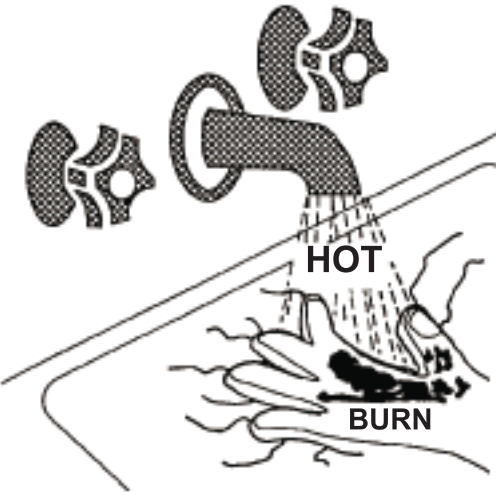

- Water temperature over 125°F (52°C) can cause severe burns instantly or death from scalds.
- Children, disabled and elderly are at highest risk of being scalded.
- See instruction manual before setting temperature at heating appliance.
- Feel water before bathing or showering.
- If this appliance is used to produce water that could scald if too hot, such as domestic hot water use, adjust the outlet control (limit) or use temperature limiting valves to obtain a maximum water temperature of 125°F (52°C).



WARNING

Should overheating occur or the gas supply fail to shut off, turn off the manual gas control valve to the appliance.



WARNING

Do not use this appliance if any part has been under water. Immediately call a qualified service technician to replace the appliance.

2A. Starting the System

1. Close the manual gas valve located outside the water heater. Turn on the power to the unit. The pump should come on immediately. Check to be sure that the pump is operating properly. If it does not, test the electrical circuits.
2. Before you open the gas supply valve, please read the safety instructions at the end of this section. These are *very important*. The burner in this unit does not require manual lighting. The pilot is controlled by a hot-surface proven-pilot ignition system (see Figure 15).
3. Open the gas supply valve. The pilot and main burners will light automatically if the tank aquastat is calling for heat.
4. In general, set the aquastat to the lowest setting which will produce water of an acceptable

temperature. This will give the most efficient operation of the water heater.

5. Once the heater is running, check the appearance of the burner flames (see Figure 14). The burners are located behind a cover on the front of the unit (see Figure 2.) If the flame has “sooting” tips, check for debris near the orifices. If the orifices are plugged, call a service technician to correct the problem.

NOTE: Safe lighting and other performance criteria were met with the gas manifold and control assembly provided on the water heater when the unit underwent the tests specified in ANSI Standard Z21.10.3.

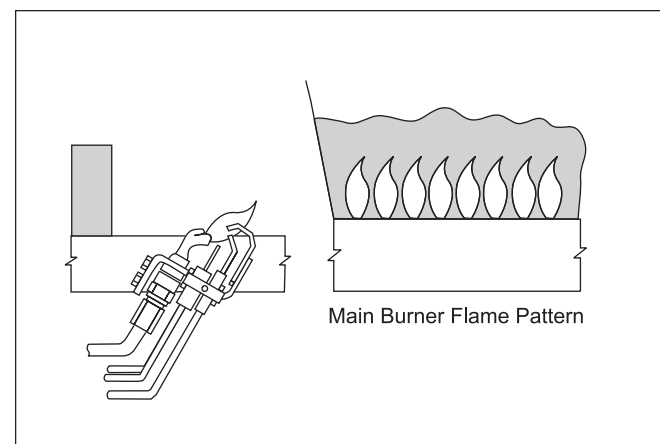

Figure 14. Flame Patterns.

2B. Starting the System After Extended Shut-Down

1. Hydrogen gas can be produced in a hot water system that has not been used for a long period of time (usually two weeks or more.) **Hydrogen gas is extremely flammable.** This gas can easily burn or explode if it is ignited by a flame or electrical spark.
2. To prevent any chance of injury, you must take special precautions when starting the unit after a long shut-down. Before you use any electrical appliance which is connected to the hot water system, you should clear any gas which has collected. **Put out any cigarettes or open flames in the area around the appliance you want to use.** Open the hot water faucet near the water heater.
3. If hydrogen is present, you may hear an unusual sound when you open the tap. This is the sound of the gas escaping through the pipe as the hot water begins to flow.
4. When the sound stops, turn off the tap. Open windows and doors in the space around the tap. Allow at least 15 minutes for the gas to clear before you use any open flames or electrical appliances.

2C. Shut-Down Procedure

1. Turn off the power to the unit.
2. Turn off the gas valve to the unit.
3. Turn off the valve on the cold water supply.

2D. Extended Shut-Down – Cold Weather Areas

If the water heater is not going to be used for long periods of time in locations where freezing occurs, it should be completely drained of all water.

1. Follow the shut-down procedure listed in Section 2C.
2. Open the drain valve on the contractor supplied water storage tank.
3. To help the draining action, hold open the pressure relief valve.
4. It is also important to drain the heat exchanger. If the heat exchanger is not drained, the water may freeze inside, and the casting may be damaged. The heat exchanger is located inside the heater on the top of the unit (see Figure 2) . Remove the sheet-metal covers. Each side of the heat exchanger includes two rows of brass plugs. To drain the heat exchanger, remove any two of the brass plugs in the lower rows.
5. Before starting the system, refill the system (contractor supplied tank) with water. Follow the procedure in Section 1P. When refilling the unit, remember to replace the brass plugs and release the pressure relief valve.

FOR YOUR SAFETY READ BEFORE OPERATING

⚠ WARNING: If you do not follow these instructions exactly, a fire or explosion may result causing property damage, personal injury, or loss of life.

- A. This water heater is equipped with an ignition device that automatically lights the pilot. Do not try to light the pilot by hand.
- B. BEFORE OPERATING, smell all around the water heater area for gas. Be sure to smell next to the floor because some gas is heavier than air and will settle on the floor.
- C. If you cannot reach your gas supplier, call the fire department.
- C. Use only your hand to push in or turn the gas control knob. Never use tools. If the knob will not push in or turn by hand, don't try to repair it. Call a qualified technician. Force or attempted repair may result in a fire or explosion.
- D. Do not use this water heater if any part has been under water. Immediately call a qualified service technician to replace the unit.

WHAT TO DO IF YOU SMELL GAS

- Do not try to light any appliance.
- Do not touch any electric switch. Do not use any phone in your building.
- Immediately call your gas supplier from a neighbor's phone. Follow the gas supplier's instructions.

OPERATING INSTRUCTIONS

1. STOP! Read the safety information above on this label.
2. Set the aquastat to lowest setting.
3. Turn off all electric power to the water heater.
4. This water heater is equipped with an ignition device which automatically lights the pilot. Do not try to light the pilot by hand.
5. Set the ignition system control switch to the full "OFF" position.
6. Wait five (5) minutes to clear out any gas. If you then smell gas, STOP! Follow "B" in the safety information above. If you don't smell gas, go to next step.
7. Set the ignition system control switch to "ON".
8. Set aquastat to desired setting.
9. Turn on all electric power to the appliance.

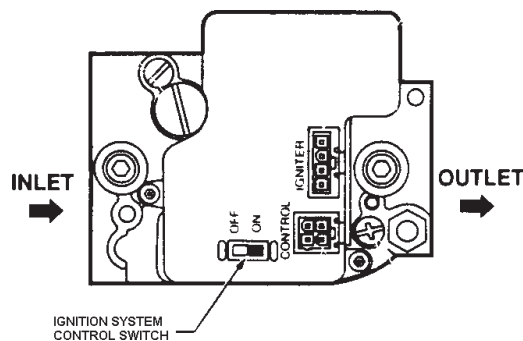

Honeywell SV9501/9601 Gas Valve

10. If the appliance will not operate, follow the instructions "To Turn Off Gas To Appliance" and call your service technician or gas supplier.

TO TURN OFF GAS TO WATER HEATER

1. Set the aquastat to lowest setting.
2. Turn off all electric power to the water heater if service is to be performed.
3. Turn the ignition system control switch to "OFF."

SECTION 3. Maintenance and Service

WARNING

Follow local regulations with respect to installation of carbon monoxide (CO) detectors. To reduce the risk of CO spillage, follow the maintenance schedule for the water heater.

3A. Regular Maintenance

Do this immediately after installation

- Inspect the external surfaces of the heat exchanger for fouling. This could indicate a problem with the supply of combustion air. Inspect again on this schedule:
 - 24 hours
 - 7 days
 - 30 days
 - 90 days
 - Once every six months thereafter
- Keep the area around the water heater clear. Remove any combustible materials, gasoline, or any flammable vapors and liquids.
- Be sure that all openings for combustion and ventilation air are not blocked.

Do this at least once a year

- Have the unit inspected by a qualified service technician. See Section 3B.
- Lubricate the water circulating pump. Follow the instructions supplied with the pump.
- If a strainer is employed in a pressure reducing valve or the piping, clean it.
- Check the burner and pilot flames (see Figure 13). Do this at start-up, and check regularly afterwards. If the flame has “sooting” tips, check for debris near the orifices. If the orifices are plugged, call a service technician to correct the problem.
- Inspect the venting system for obstructions, leakage or corrosion.
- Drain a few gallons of water out of the bottom of the tank. This will remove any sediment which has collected.

3B. Recommended Annual Inspection

The gas and electric controls on the water heater are engineered for long life and dependable operation. All of the controls and safety devices must be working

correctly for the unit to operate safely. Natco *strongly recommends* that the basic items listed below be checked by a qualified service technician every year.

- Water temperature controls
- Pilot safety system
- Automatic gas valves
- Pressure switch (inducer fan proving switch)
- Inducer/blower assembly
- Check function of pressure relief valve
- Check/clean screen in flue collector assembly

NOTE: The warranty does not cover damage caused by lack of required maintenance, lack of water flow, or improper operating practices.

3C. Cleaning the Heat Exchanger

If the heat exchanger must be cleaned, follow this procedure:

1. Shut off all power to the water heater.
2. Remove the venting top, flue collector, draft inducer assembly, and heat exchanger baffles.
3. Remove the burner tray.
4. Clean any soot and loose scale from the outside of the heat exchanger. Use a hand-operated spray bottle filled with water, and a wire brush. **Do not use compressed air, high-pressure water, or a garden hose.** (This could damage the combustion chamber.)
5. Clean out any debris which has fallen to the bottom of the unit.
6. Check to make sure the burner ports and the pilot assembly are free of debris before returning the burner tray to its original position.
7. Reassemble the water heater in the reverse order. **Be sure to replace the baffles in the heat exchanger.**

3D. Operating Sequence

Figure 2 and Figure 11 show the locations of the parts and sensors used on this heater.

1. At the beginning of the cycle, the contractor supplied tank contains heated water. The remote tank aquastat is satisfied, so the burner is not firing.
2. When a hot water tap is opened, hot water is drained from the tank. This is replaced by cold water, which enters the bottom of the tank.

3. There is an aquastat mounted near the bottom of the tank. Eventually the water temperature at the aquastat drops below the set point, and the aquastat calls for heat.
4. When the aquastat calls for heat, the tank circulator starts. (Notice that this happens before the burner lights.) The water circulates through the tank, and through the heater.
5. The pilot and main burners will then light, but only if these conditions are satisfied:
 - Aquastat closed – indicates the tank temperature is below the set-point.
 - High limit switch closed – indicates the water temperature in the heater is below the high limit set-point.

If all of these conditions are satisfied, the inducer motor relay turns on the inducer fan.

6. The pressure switch closes, indicating that the inducer fan is running. The pressure switch sends 24 volts to the flame rollout switch. In normal conditions, the flame rollout switch is closed.
7. There is no continuously-burning pilot in this unit. The pilot is lit each time the control system calls for heat. At the start of the lighting process, the gas valve/controller opens and the igniter element glows. This lights the pilot flame.
8. The pilot flame produces a small electrical current which is detected by the gas valve/controller. Once the gas valve/controller detects this current, the main burners light.
9. The main burners continue to run until the tank aquastat reaches the set-point temperature. Then the gas valve closes, and the draft inducer turns off. After a short time delay, the pump turns off.
10. When the tank temperature at the aquastat falls below the set-point, the cycle repeats.

3E. Cleaning the Pilot and Main Burners

This unit should not require cleaning very often. If cleaning is necessary, the unit is designed so the burners may be removed easily.

1. Turn off the gas at the manual gas valve.
2. On the front of the unit, a face plate covers the ends of the burners. Undo the four thumbscrews and remove the face plate.
3. Disconnect the white Molex® connector which runs to the gas valve.

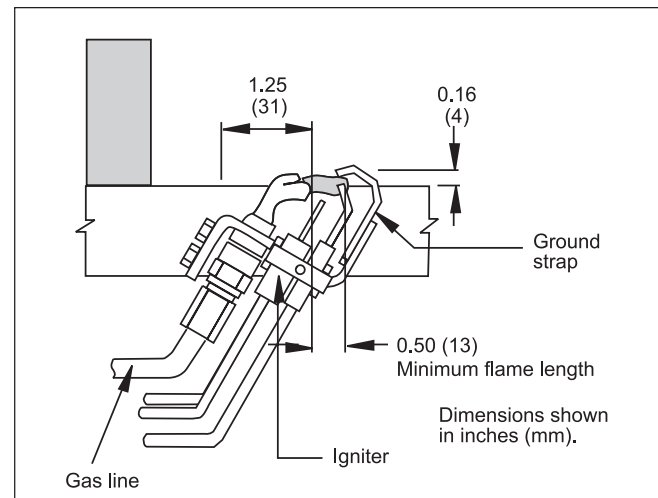

Figure 15. Pilot Assembly.

4. Disconnect the gas manifold.
5. The burners are mounted on a sliding tray. Pull out this tray to reach the burners.
6. The pilot is mounted on the right side of the assembly. Clean the pilot if the flame appears to be yellow or smoky, if the gas flow seems to be restricted, or if the pilot takes a long time to light. If you see signs of fouling, clean the assembly very gently using a bristle brush.

NOTE: Be very careful not to clean the tip of the hot surface unit. (This is located in the center of the pilot assembly.) This part is very delicate.
7. In order to clean the pilot orifice itself, you must remove the part from the bracket. Gently clean out the center of the orifice using a small wire.
8. Check the main burners. They should be cleaned if they are dirty, or if the flames are yellow or smoky. Brush off the top of each burner using a bristle brush.
9. An orifice is located at the end of each burner. To clean one of these parts, you must remove it. Gently clean out the center of the orifice using a small wire.
10. Once the burners have been pulled out, you can reach up and clean the underside of the heat exchanger.
11. Reassemble the burners and the pilot. Reassemble the gas manifold, and reconnect the pilot connector. Replace the cover plate.
12. Turn on the gas valve. Check for gas leaks before you use the water heater.

3F. Electrical Troubleshooting

The procedure listed on the next page allows you to quickly check the key parts of the electrical and control systems. You will need a volt-ohmmeter to perform these tests.

 **WARNING**

Disconnect the power supply to the boiler before doing any electrical work. Electrical shock can cause severe personal injury or death.

 **Caution**

Label all wires prior to disconnection when servicing controls. Wiring errors can cause improper and dangerous operation. Verify proper operation after servicing.

See the wiring diagram in Figure 12. Figures 2 and 11 show the locations of the parts in the unit. To reach the control wiring, remove the control box cover on the front of the water heater.

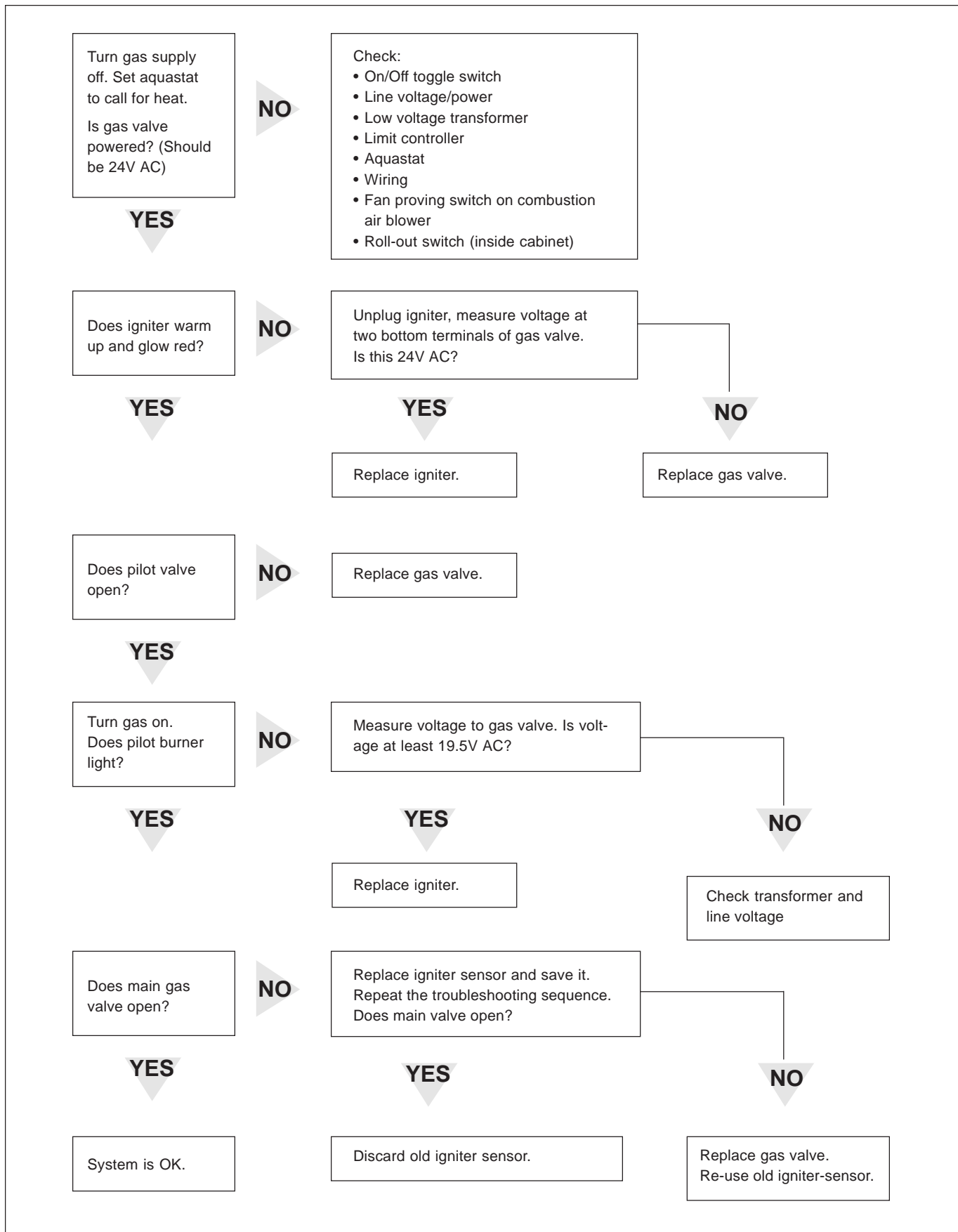

Figure 16. Troubleshooting Flowchart.

3G. Parts Listing

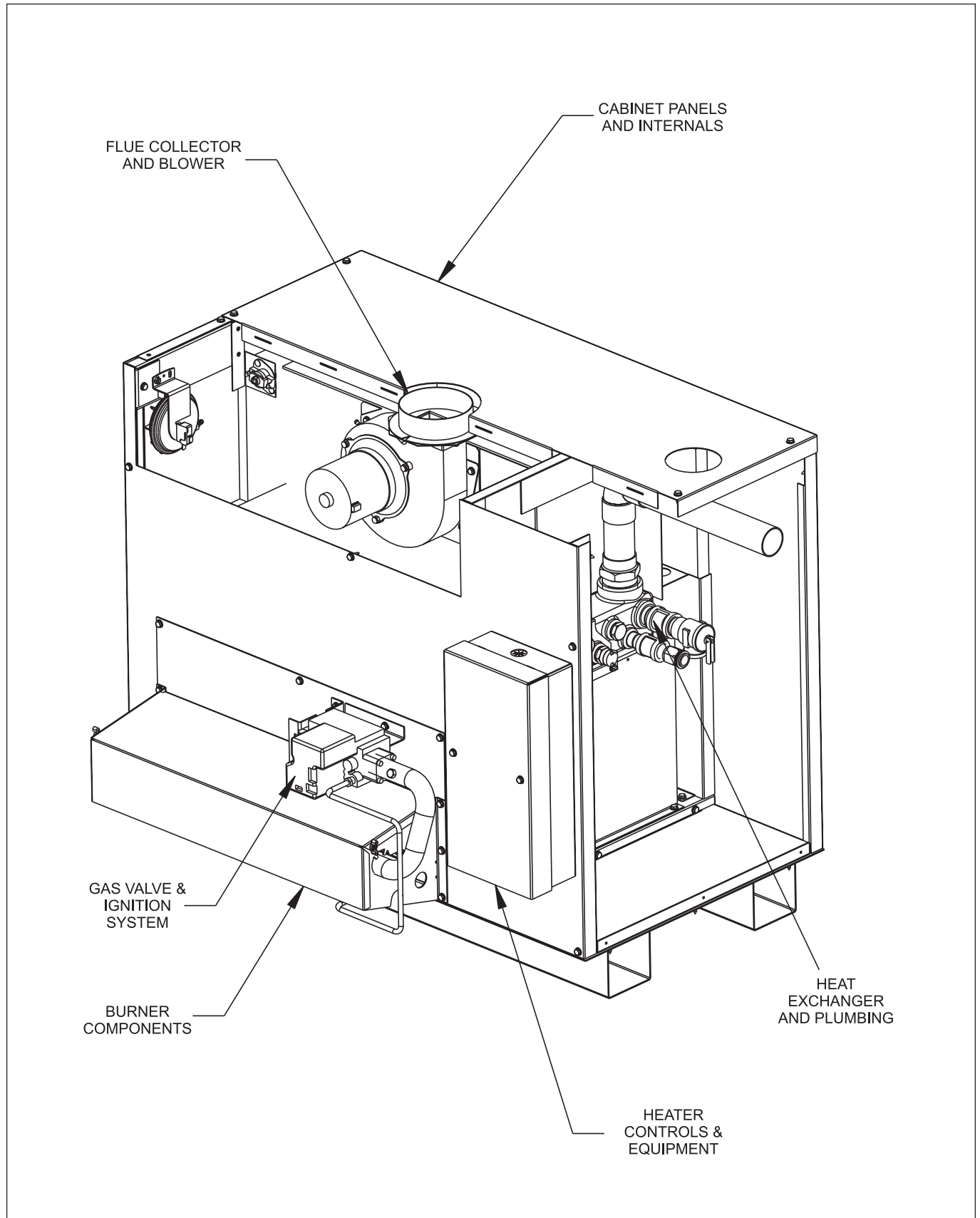
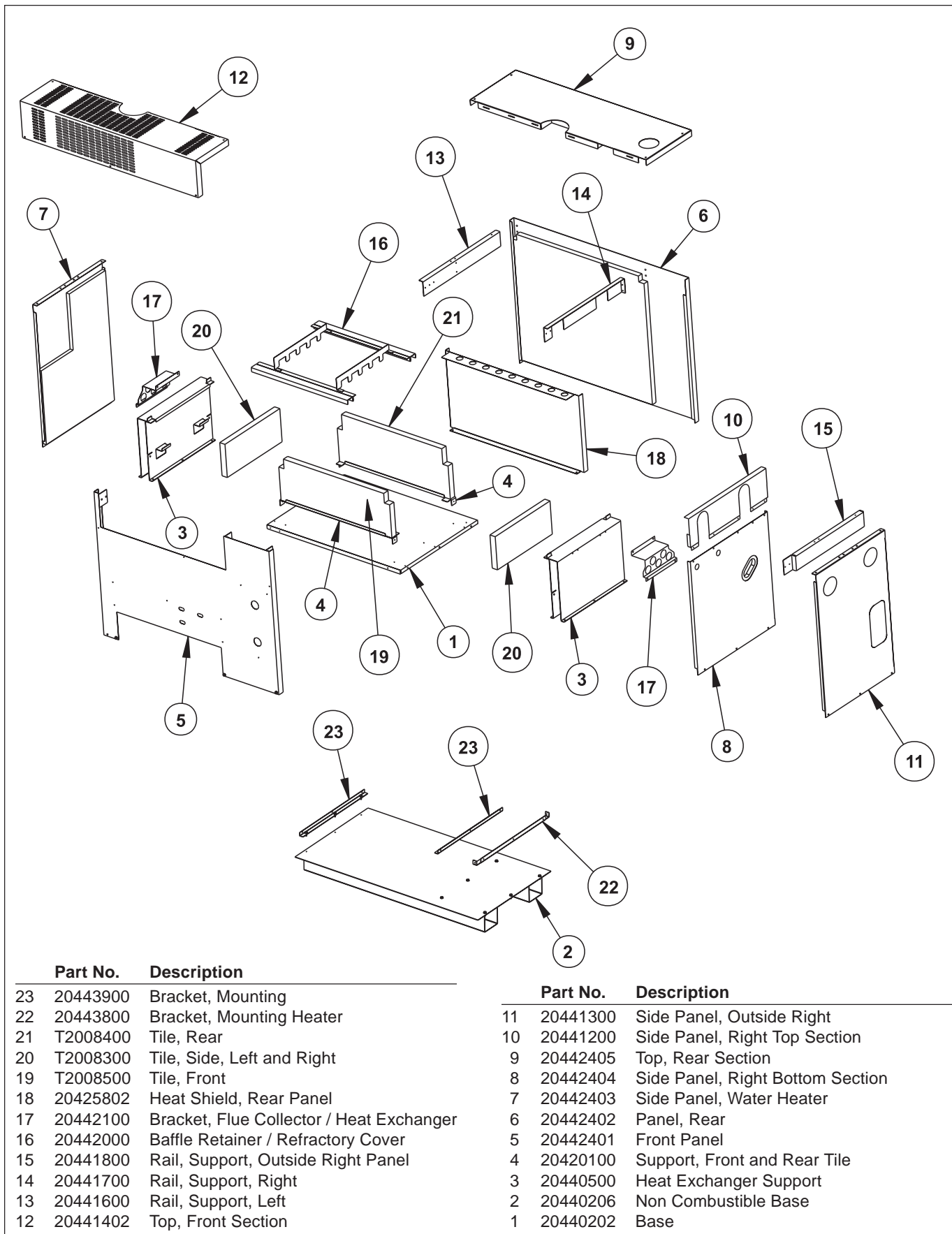

Figure 17. General View Showing Major Assemblies/Components.



Part No.	Description
23	20443900 Bracket, Mounting
22	20443800 Bracket, Mounting Heater
21	T2008400 Tile, Rear
20	T2008300 Tile, Side, Left and Right
19	T2008500 Tile, Front
18	20425802 Heat Shield, Rear Panel
17	20442100 Bracket, Flue Collector / Heat Exchanger
16	20442000 Baffle Retainer / Refractory Cover
15	20441800 Rail, Support, Outside Right Panel
14	20441700 Rail, Support, Right
13	20441600 Rail, Support, Left
12	20441402 Top, Front Section

Part No.	Description
11	20441300 Side Panel, Outside Right
10	20441200 Side Panel, Right Top Section
9	20442405 Top, Rear Section
8	20442404 Side Panel, Right Bottom Section
7	20442403 Side Panel, Water Heater
6	20442402 Panel, Rear
5	20442401 Front Panel
4	20420100 Support, Front and Rear Tile
3	20440500 Heat Exchanger Support
2	20440206 Non Combustible Base
1	20440202 Base

Figure 18. Heater Cabinet Components.

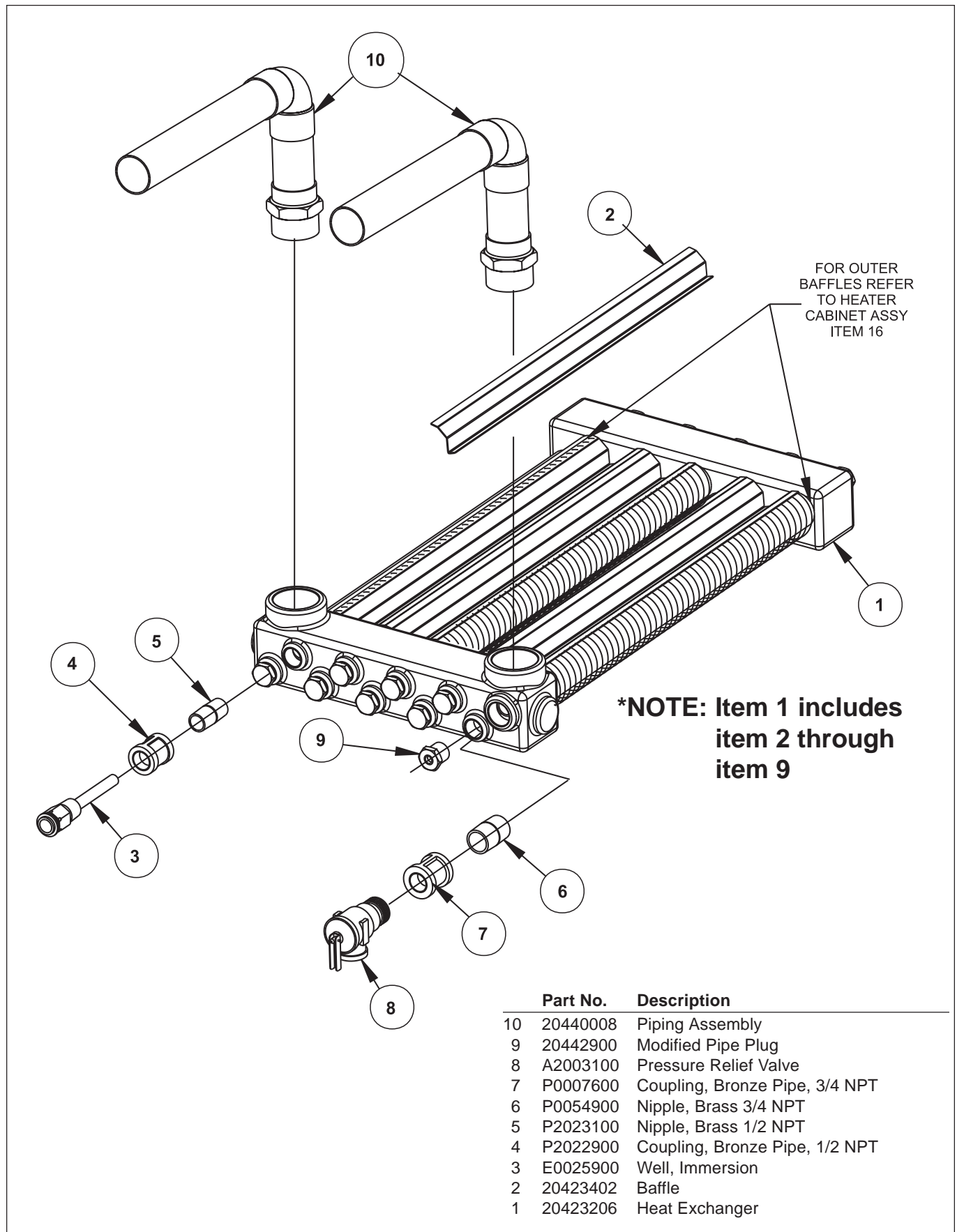

Figure 19. Heat Exchanger and Piping.

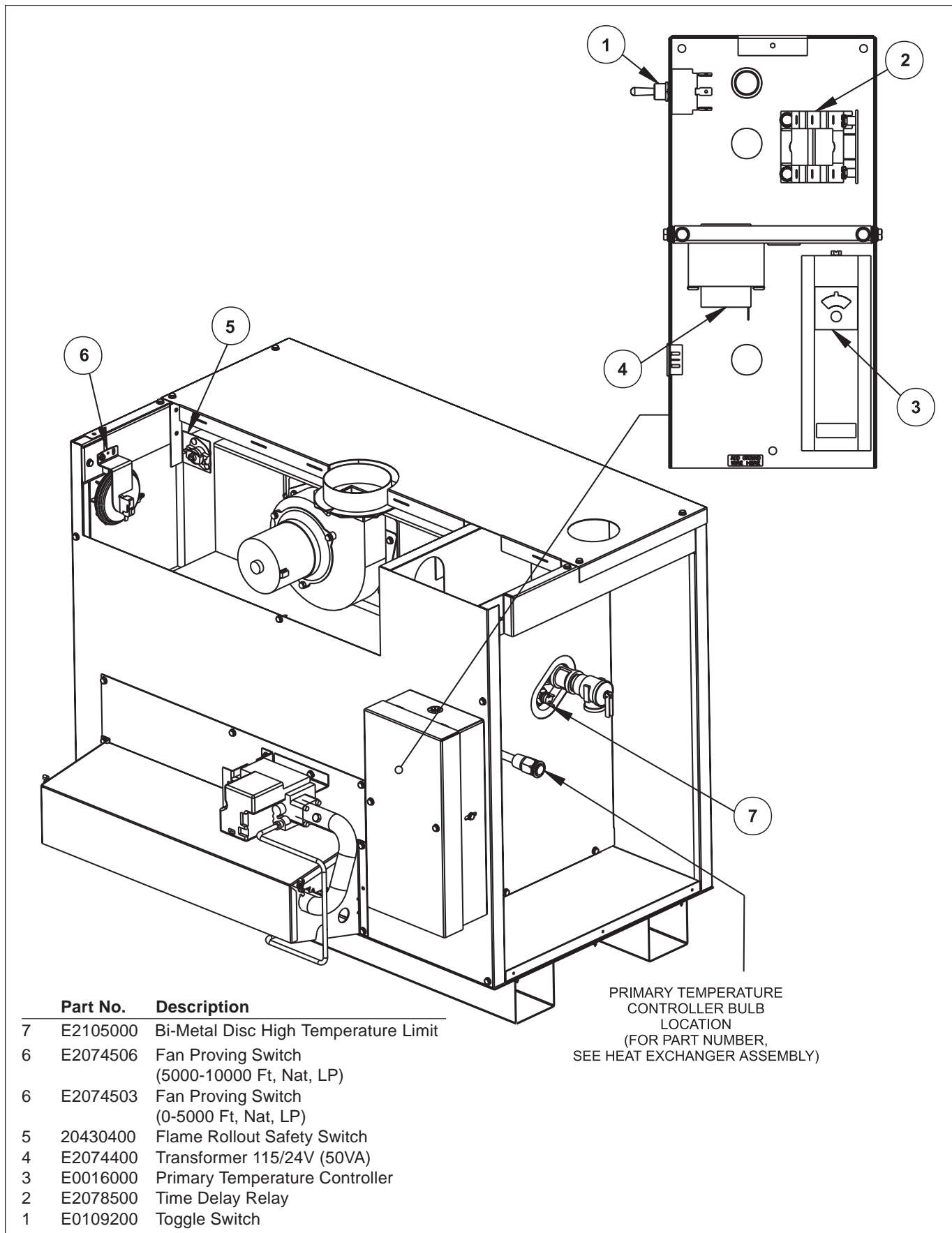
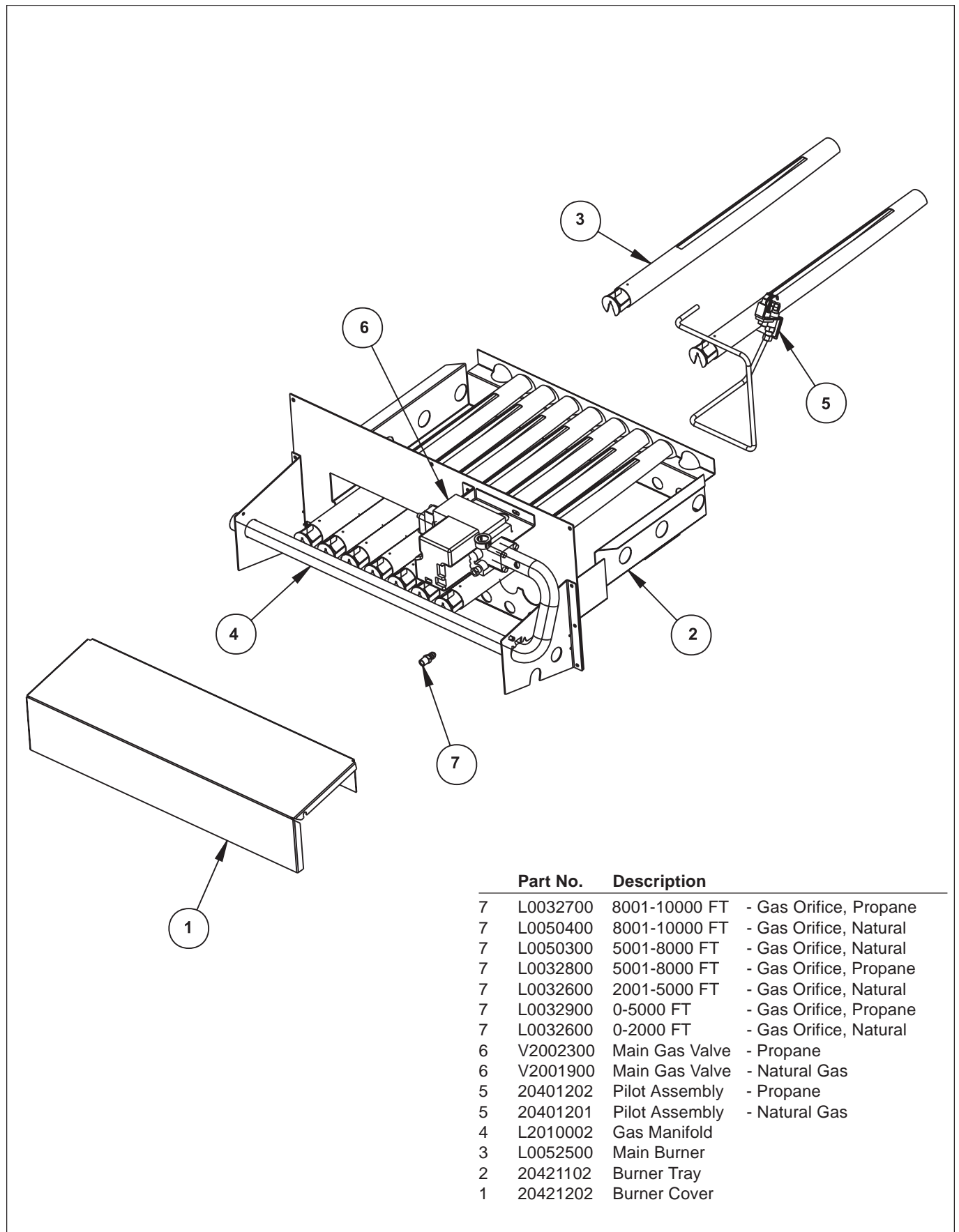
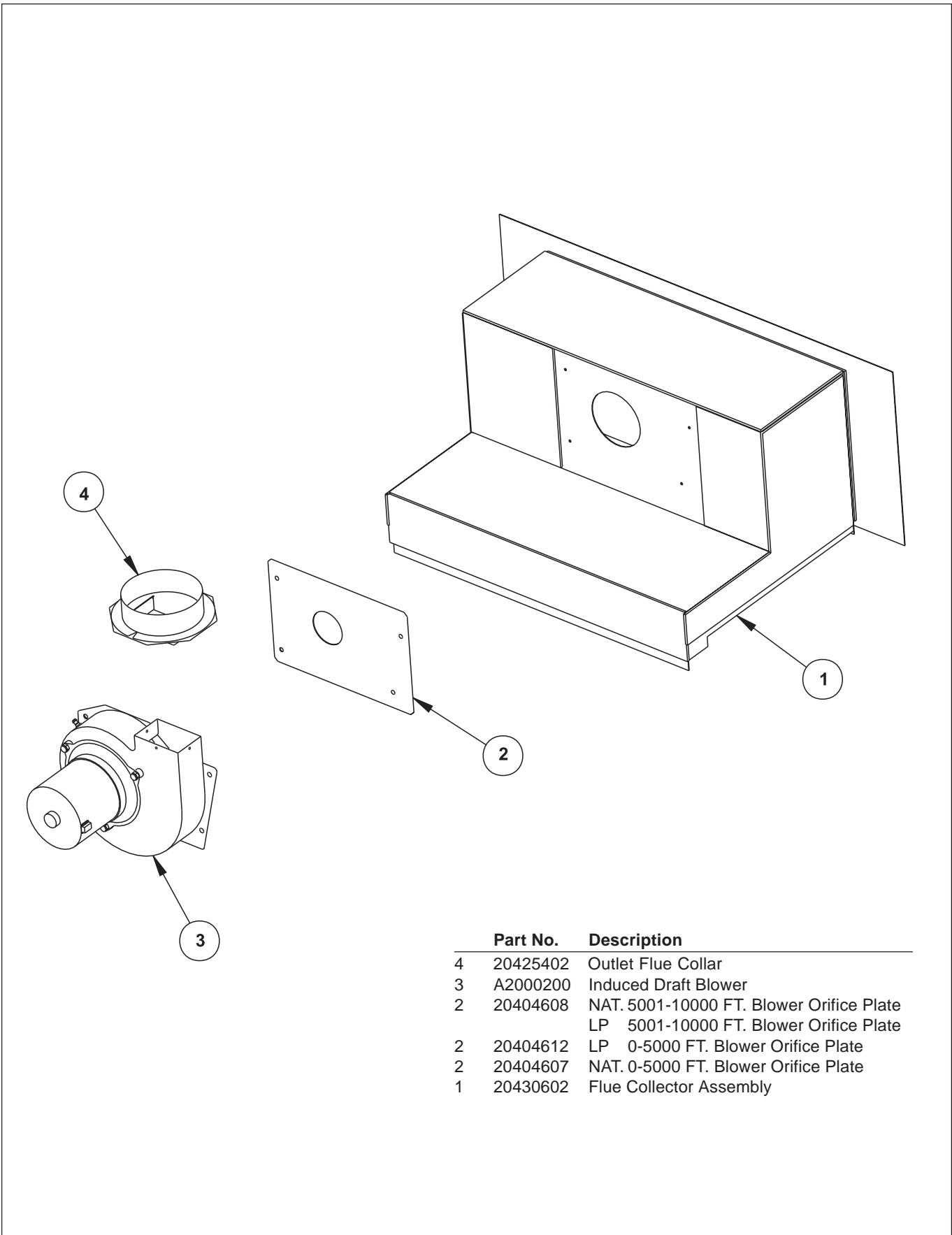

Figure 20. Electrical/Control Components.



Part No.	Description
7	L0032700 8001-10000 FT - Gas Orifice, Propane
7	L0050400 8001-10000 FT - Gas Orifice, Natural
7	L0050300 5001-8000 FT - Gas Orifice, Natural
7	L0032800 5001-8000 FT - Gas Orifice, Propane
7	L0032600 2001-5000 FT - Gas Orifice, Natural
7	L0032900 0-5000 FT - Gas Orifice, Propane
7	L0032600 0-2000 FT - Gas Orifice, Natural
6	V2002300 Main Gas Valve - Propane
6	V2001900 Main Gas Valve - Natural Gas
5	20401202 Pilot Assembly - Propane
5	20401201 Pilot Assembly - Natural Gas
4	L2010002 Gas Manifold
3	L0052500 Main Burner
2	20421102 Burner Tray
1	20421202 Burner Cover

Figure 21. Burner Tray Assembly.



	Part No.	Description
4	20425402	Outlet Flue Collar
3	A2000200	Induced Draft Blower
2	20404608	NAT. 5001-10000 FT. Blower Orifice Plate LP 5001-10000 FT. Blower Orifice Plate
2	20404612	LP 0-5000 FT. Blower Orifice Plate
2	20404607	NAT. 0-5000 FT. Blower Orifice Plate
1	20430602	Flue Collector Assembly

Figure 22. Flue Collector Assembly.



National Combustion Co., Inc.
104-11 180th Street, Jamaica, NY 11433 • 718.291.8400 • FAX 718.291.6870

www.nationalcombustion.com

